

INDIVIDUAL AND RELIABLE SOLUTIONS FOR PROCESS GASES



AERZEN

CONTENTS



03 Individual and reliable processes.
AERZEN premium in every process.



04 Industries and key applications.
Sometimes critical. Always challenging.



06 Secure the leading edge.
Compression under the best conditions.



08 Engineering.
From the application to your high-end solution.



10 VR Process gas compressor.
Maximal volume. Oil-free compression.



11 VMY process gas compressor.
Highest pressures. Full flexibility.



12 GR process gas blower.
Maximal safety. Oil-free handling.



13 GQ process gas blowers.
A tough endurance runner.



14 High-pressure blowers GM dz.
Gas booster at the high-pressure level.



15 Low-pressure blower GMd.
Gas booster for low pressure applications.



16 At a glance.
Variety for every application.



18 Everything - except ordinary.
The service world of AERZEN.

INDIVIDUAL AND RELIABLE PROCESSES.

AERZEN – Premium in every process.

Where gases are compressed in highly-critical processes, there are few tolerances. Process gas solutions must meet highly specific requirements. Just as strict laws and guidelines. Above all, they must ensure one thing: A reliable, uninterrupted and economic production process. Under any conditions. In all applications, industries, and countries of the world.

AERZEN is one of the pioneers in compressor technology. Discuss machine solutions with our experts and benefit from more than 150 years of know-how and experience. From an unusually broad solution portfolio. From the consistent focus on efficiency criteria. From extremely long service life. And from the international profile of a global player.

The right plant for every application.

We develop ground-breaking solutions and overall concepts in more than 100 countries of the world. Process gas compressors and blowers, modifications, accessories and special developments that have proven themselves in more than 10,000 installed plants worldwide. Market-leading solutions that significantly contribute to your company's success.

No matter whether you're looking to optimise, modernise, or construct plants. Benefit from this in every individual application. In every specific process. In each of your questions:

- How do you secure the productivity of your process gas plant and consequently your business success?
- What requirements do modern process gas machines have to meet today?
- What sets compressor solutions from AERZEN apart?

On the following pages, we would like to provide you with our answers to these and other questions.



LET'S TALK

„... about **individual** and **reliable** processes, tailored to your application.“

INDUSTRIES AND KEY APPLICATIONS. SOMETIMES CRITICAL. ALWAYS CHALLENGING.

AERZEN offers the process gas industries an enormously broad spectrum of blower and compressor technologies – perhaps the broadest of all. The machines work in all industrial key applications on a stand-alone basis, in machines or containers, onshore and offshore.

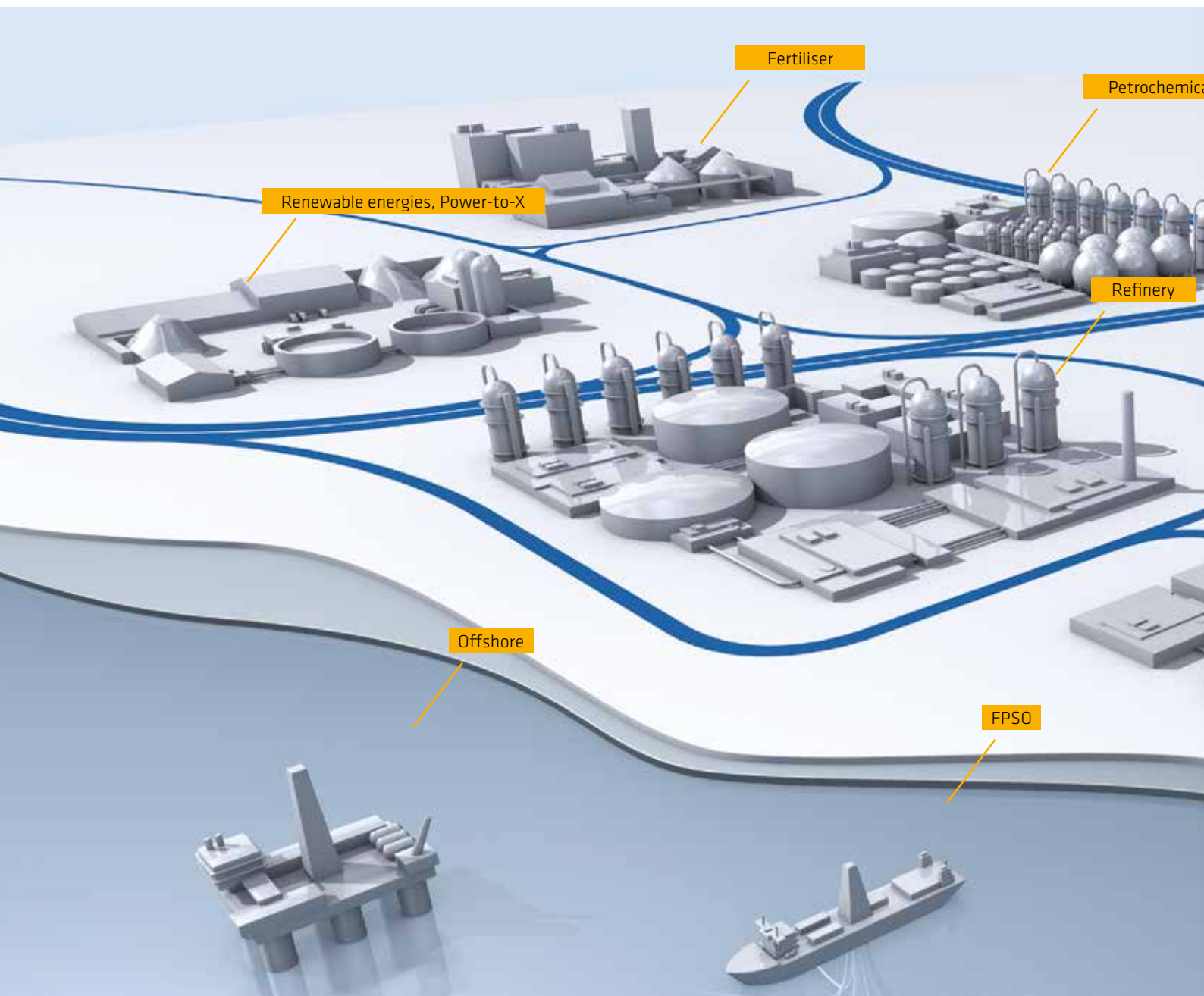

Industrial gases

- Air separation
- Synthetic gases

Chemical process industry

- Methanol synthesis
- Ammonia synthesis
- Ammonia liquefaction
- Sodium production
- Lime kiln gas compression, combustion gas compression
- Reduction gas catalysts
- Acetylene circular gas

Petrochemicals, refineries

- PSA feed gas, tail gas
- Flare gas compression
- Ethylene, propylene, olefin
- Butadiene
- Styrene off gas

Industrial research and development

- Circular processes
- Helium compression in cryo plants

Energy production

- Turbine charging
- Steam compression
- Biogas block-type thermal power station

Glass industry

- Oxygen blowers
- Tin bath protective atmosphere

Nuclear

- Vapour recompression
- Boron recycling

Oil/gas extraction and storage

- Natural gas, crude gas
- Acid gas, hydrogen sulphide, Claus gas
- Pipeline booster, compressor charge
- Gas recovery
- Boil-off gas compression
- VOC compression
- Propane, butane booster
- Helium recovery
- Decarbonisation

Coal, iron, and steel

- Coke oven gas compression
- (Blast) furnace gas
- Process and cooling gas in iron direct reduction
- Purge gas compression direct reduction kilns

- Hydrogen reduction
- Oxygen blowers

Renewable energies, Power to X

- Hydrogen network feed-in
- Oxygen use
- Synthesis gas compression
- Production of biomethane

Refrigeration technology

- Compression of organic and inorganic coolants
- Refrigeration circuits

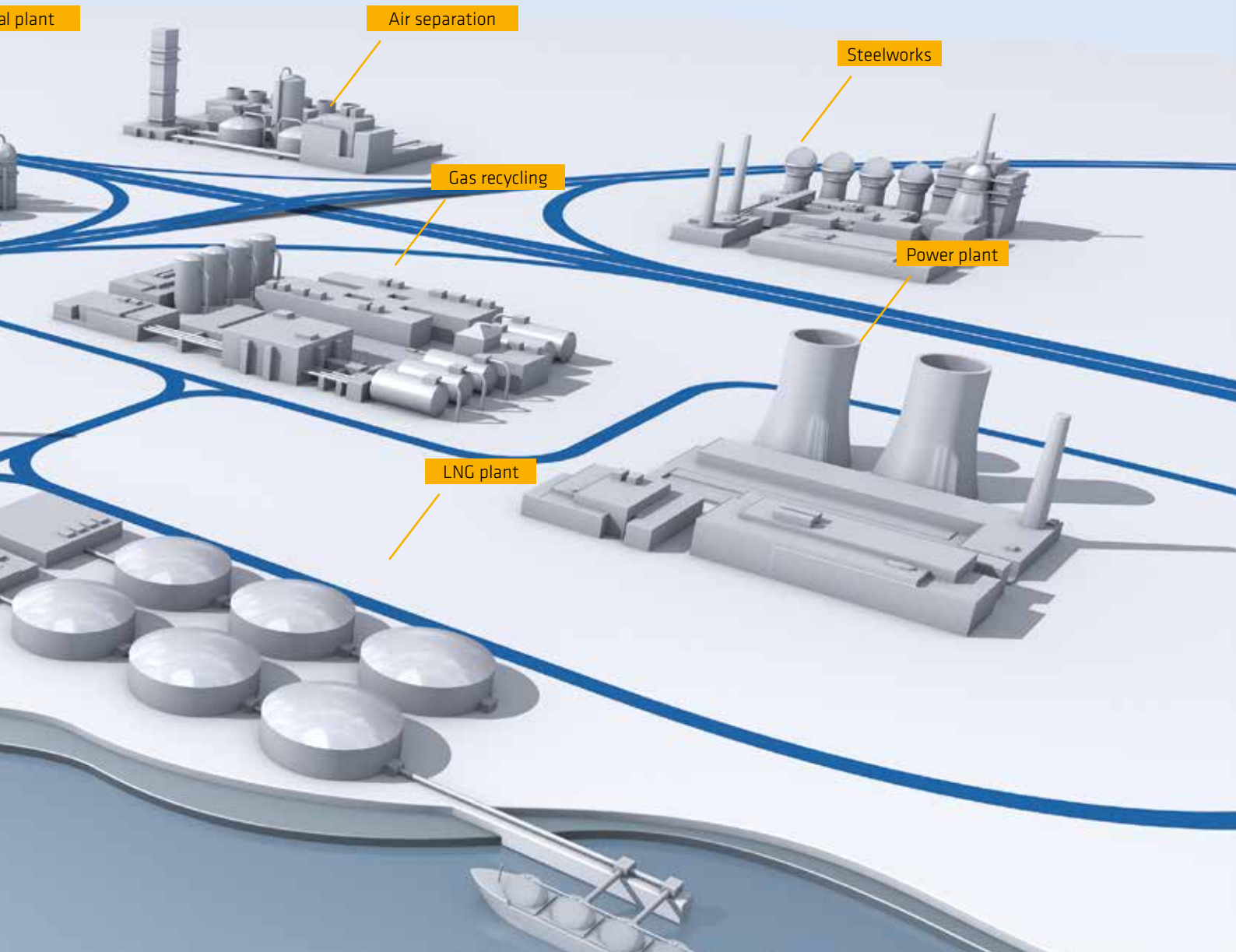

SECURE THE LEADING EDGE. COMPRESSION UNDER THE BEST CONDITIONS.

We want to offer you the best solutions. Highly developed blowers and compressors for the process gas industry. Unbeatable in terms of quality and service life. Impressive reliability and availability. Tailor-made to your respective process conditions – resulting in ground-breaking efficiency.

Reliability. Premium quality made in Germany.

AERZEN stands for premium technologies. And with it for an extraordinarily high quality level with global standardisation. Global quality standards were set up and certified in an integrated management system to guarantee this. Consisting of components such as DIN EN ISO 9001 (quality management), 14001 (environmental management), and 50001 (energy management), as well as OHSAS 18001 (occupational health and safety management).

Just like certified design processes and a wide range of special certifications. The headquarters in Germany is responsible for worldwide quality control of the company group. What do you have from it? High reliability in plant operation. Extremely long availability. And the certainty of being able to rely on the quality promise “Made in Germany – Made by AERZEN”. Regardless of where our machines are in use all over the world.

Safety. That you rely on.

Regardless of type of construction, sizes, and special designs, our highly developed machines are configured to comply with all relevant international requirements, building regulations, or specifications of the most diverse industries or inspection companies. From A to Z. In all countries. This includes ASME,

API, TEMA, ANSI, Ex, and DIN. Or the European Pressure Equipment Directive (PED). And, of course, the relevant safety directives for electrical plants such as DIN, EN, NEMA, IEC and ATEX. Certifications that put your mind at ease: Wherever our machines work- with AERZEN, you are on the safe side.

Efficiency. Right-sized for your process.

Energy efficiency is one of the main requirements for modern compressor technology. No wonder, seeing as how the energy share of the total life cycle costs of such plants is about 80%. This is why energy consumption reduction is a core objective of AERZEN. To your benefit. For example, with blower and compressor types precisely designed for optimum flow. With high efficiency, innovative component developments, and the extraordinarily wide portfolio of gearbox variants. The decisive factor in minimising energy consumption still remains: Each AERZEN compressor and blower package is tailor-made. Individually tailored to your specific process. Right-sized – and uniquely efficient.

„EVERY SOLUTION BY AERZEN IS INDIVIDUAL.
BESPOKE FOR THE SPECIFIC REQUIREMENTS OF
OUR CUSTOMERS.“

REFERENCES.

INTERNATIONAL PROJECTS.



GMB 19.19HV

Combustion-gas vacuum blower in Ziegler alcohol synthesis

Volume flow: 20,700 m³/h

Pressure range: 30 mbar to 100 mbar (a)



GQ 22.23xz

Process gas booster in MIDREX processes

Volume flow: 300,000 m³/h

Pressure range: 1.2 to 3.2 bar (a)

(3 + 2 stage configuration)



VRa 736S

Coke oven gas compressor in integrated steel mill

Volume flow: 10,100 m³/h

Pressure range: 1.0 to 4.0 bar (a)



GRa 20.f20x

Handling of coke oven and blast furnace gas in steelworks

Volume flow: 22,500 m³/h

Pressure range: 1.1 to 2.1 bar (a)

(3 stage parallel)

ENGINEERING. FROM APPLICATION TO YOUR HIGH-END SOLUTION.

It's not the machine that determines the process – it's the process that determines the machine. This is our philosophy. Reflecting on application the AERZEN way means investing a lot of effort in preparations to understand the business of its customers. At our Engineering Center, we use this to create high-performance solutions. State-of-the-art technologies for the most demanding process gas applications in a wide range of industries.



Highly efficient high-end solutions for the process gas industry are created in the AERZEN Engineering and Production Center. This is a single-stage assembly of the VMY series.

Connecting skills. The Engineering Center.

Process gas plants must operate in the most demanding industries. The requirements placed on performance and technical design are correspondingly high. To meet these requirements, we bundle all of our technical expertise at the AERZEN Engineering Center Germany, home to a team of excellently trained specialists.

Experts with international experience in all fields of process gas compression and handling. Our research and development activities and all engineering expertise is bundled here as well – from design to measurement, regulation, and electrical engineering. For good reason. This is to ensure that our solutions meet the high quality standards you associate with the demands made on AERZEN.

Engineering services from AERZEN:

- ✓ Calculations of process data (drive power, cooling consumption, etc.)
- ✓ Preparation of starting curves for drive design
- ✓ Acoustic calculations
- ✓ Torsion and bending-critical calculations
- ✓ Piping calculations included
- ✓ Earthquake calculations
- ✓ Advising on all safety issues of the customer (e.g. HAZOP studies)
- ✓ Re-engineering, constructive and electrotechnical

Understanding your process.

More than 150 years of know-how in the development of compressor technologies, more than 10,000 successfully implemented process gas plants in nearly all industries and applications worldwide – there is virtually no application that AERZEN has not found a solution for. Why does AERZEN invest so much in your task? Each and every time? Because the performance of the machine determines the performance

of the production process. Because your markets and production processes make the small but crucial difference. Because professionalism, experience, and an eye for detail determine success. And because we see your trust as a mandate to support you with the best machine solution that can currently be built.



One partner. In all phases of the project.

Our engineering teams accompany your plant development through all phases of the project. From the first site inspection until long after commissioning. As your point of contact, they take over responsibility for your project. In all areas of system design. Comprehensive – from project

management and coordination up to quality control and system integration, documentation, and certification, packing and shipment, maintenance and service. Your project from a single source – we want to make sure that our turnkey products not only meet your requirements: We want to inspire you along the line.

VR PROCESS GAS COMPRESSOR. MAXIMAL VOLUME. OIL-FREE COMPRESSION.

Oil-free compression for small and large volume flows, for nearly all gases: The dry screw compressors from AERZEN are extremely versatile. Gear ratios and speed controls maximise the already large field of applications. A multitude of proven seal concepts and the completely separated oil chambers guarantee smooth continuous operation - even with contaminated or polymerising gases. With vertical direction of flow for high water injection quantities. Applications include cooling, cleaning, and increasing volumetric or isentropic efficiency. VR compressors from AERZEN are the ideal choice for fluctuating operating states and oil-incompatible gases.

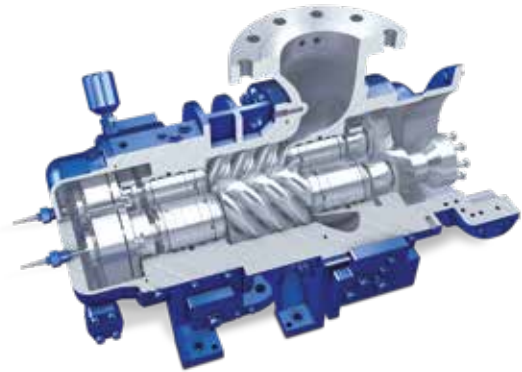

Compressor oil-free



Volume flows from
650 to 120,000 m³/h



Negative pressure: -900 mbar
Positive pressure: 52 bar g
(Higher pressures upon request)



Conveying media:
Neutral, toxic,
flammable, corrosive gases,
or mixed gases.

Volume flows Q_v (m³/h)

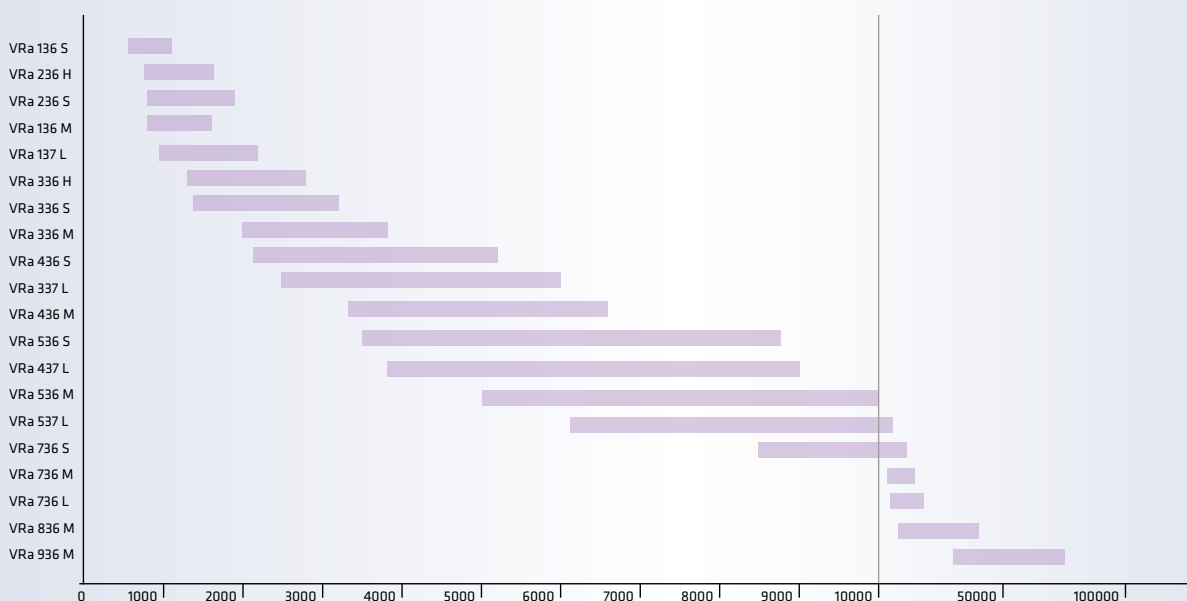

L long, M medium, S short, H high pressure

VMY PROCESS GAS COMPRESSOR. HIGHEST PRESSURES. FULL FLEXIBILITY.

They supply the highest differential pressures or pressure ratios in the AERZEN product portfolio – the oil flooded compressor series VMY. The flow rate can be continuously controlled via the control slider and can also be used as a start unloading device. The rotor drive is not effected by means of timing gears (as with oil-free compressors), but by means of direct power transmission of the driven rotor. The oil injection quantity regulates the outlet temperature and, in case of humid gases, it is ensured that the oil is always compressed above the specific dew point temperatures. This reliably prevents water from escaping into the oil/gaseous mixture. Designed for years of continuous operation, VMY compressors are the ideal solution for low molar weights, for coolants, and generally for fluctuating operation conditions under high pressure ratios.



Oil-injected
compressor



Volume flows from
233 to 8,910 m³/h



Negative pressure: -900 mbar
Positive pressure: 25 bar g
(Higher pressures
upon request)



Conveying media: Neutral
and flammable gases, oil-
compatible mixed
and process gases, as well
as all common coolants

Volume flows Q_1 (m³/h)

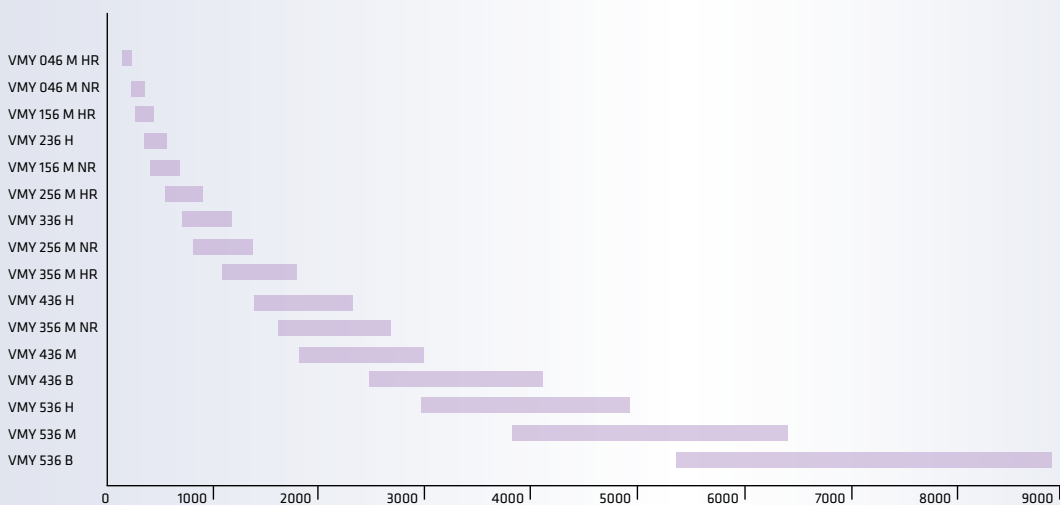

M medium, H high pressure, B booster, MR main rotor driven, SR secondary rotor driven

PROCESS GAS BLOWER GR.

MAXIMAL SAFETY.

OIL-FREE HANDLING.

The GR series is the flexible all-rounder among the Roots blowers. This series is suitable for the oil-free handling of almost all gases for small and large volume flows. The vertical direction of flow allows continuous water injection for cooling and cleaning, for efficient conveying of even highly contaminated or polymerising gases over the long term. Depending on local conditions, different sealing concepts can be selected to keep the life cycle costs to a minimum. The optimal solution, especially for oil-incompatible gases.



Blower oil-free



Volume flows from
100 to 50,000 m³/h



Negative pressure: -500 mbar
Positive pressure: 6 bar g
(Higher pressures upon request)
Differential pressure:
up to 1,500 mbar



Conveying media: Oxygen as well as neutral, toxic, combustible, corrosive gases or mixed gases.

Volume flows Q_1 (m³/h)



GQ PROCESS GAS BLOWER.

A TOUGH ENDURANCE RUNNER.

The robust high-performance machines of the GQ series have been developed for continuous operation. Adhesive or abrasive gas components are washed continuously without damaging parts in contact with the medium. The combination of oil-purged mechanical seal with an upstream, flushable labyrinth permanently separates the oil and conveying chamber – safely and effectively. Designed for multi-year continuous operation, GQ blowers are the preferred solution for process and cooling gas applications in iron direct reduction plants.



Blower oil-free



Volume flows from
15,000 to 100,000 m³/h



Negative pressure: -500 mbar
Positive pressure: 5 bar g
(Higher pressures upon request)
Differential pressure:
up to 1,500 mbar



Conveying media:
Inert, toxic, combustible,
corrosive gases or mixed
gases.

Volume flows Q_1 (m³/h)

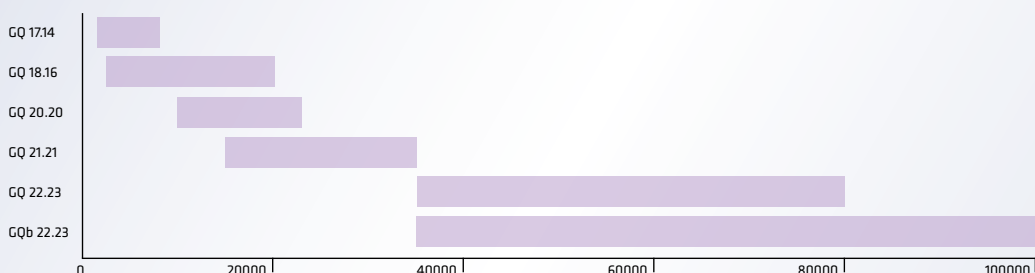

b stainless steel design

GM DZ HIGH-PRESSURE BLOWER. GAS BOOSTER AT THE HIGH-PRESSURE LEVEL.

The high-pressure series GM dz was developed for gas booster applications in closed circuits with increased inlet pressures. For explosive gases, the design pressure of 25 bar g offers the corresponding pressure shock resistance (internal Ex zone). GM dz supplies up to 2,000 mbar differential pressure. The drive shaft is sealed using single or double-acting mechanical seals.

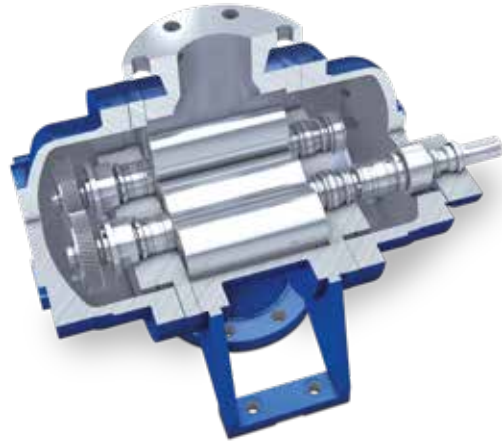

Blower oil-free



Volume flows from
60 to 6,000 m³/h



Positive pressure 25 bar g
(Higher pressures
upon request)
Differential pressure:
up to 2,000 mbar



Conveying mediums:
Inert, toxic, combustible
gases or mixed gases

Volume flows Q_1 (m³/h)

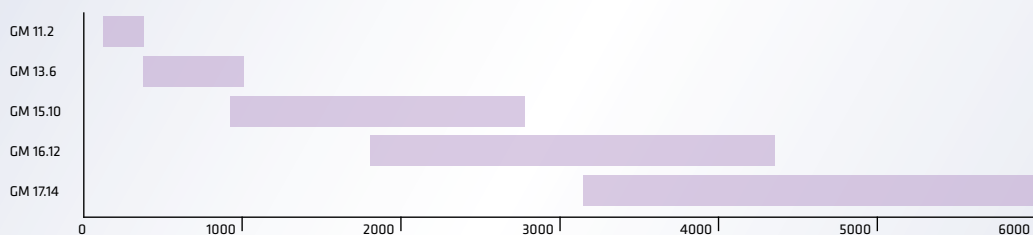

GMD PROCESS GAS BLOWER. GAS BOOSTER FOR LOW PRESSURE APPLICATIONS.

The Gmd series from AERZEN is the universal gastight booster solution for the low-pressure range. Equipped with a magnetic coupling, it guarantees a virtually maintenance-free sealing concept. There is no need for a sealing system for the drive shaft seal, for a low-maintenance machine concept. The separation between the oil and process side is effected by a special ring seal. The robust two-lobe compressors allow a design pressure of 7.0 bar g following AD2000/DIN EN 13445. 16 sizes ensure optimal efficiency and operation conditions for each design case.



Blower oil-free



Volume flows from
60 to 14,000 m³/h



Positive pressure 7 bar g
(Higher pressures
upon request)
Differential pressure:
up to 1,000 mbar



Conveying media:
Inert, toxic, combustible
gases, or mixed gases

Volume flows Q₁ (m³/h)

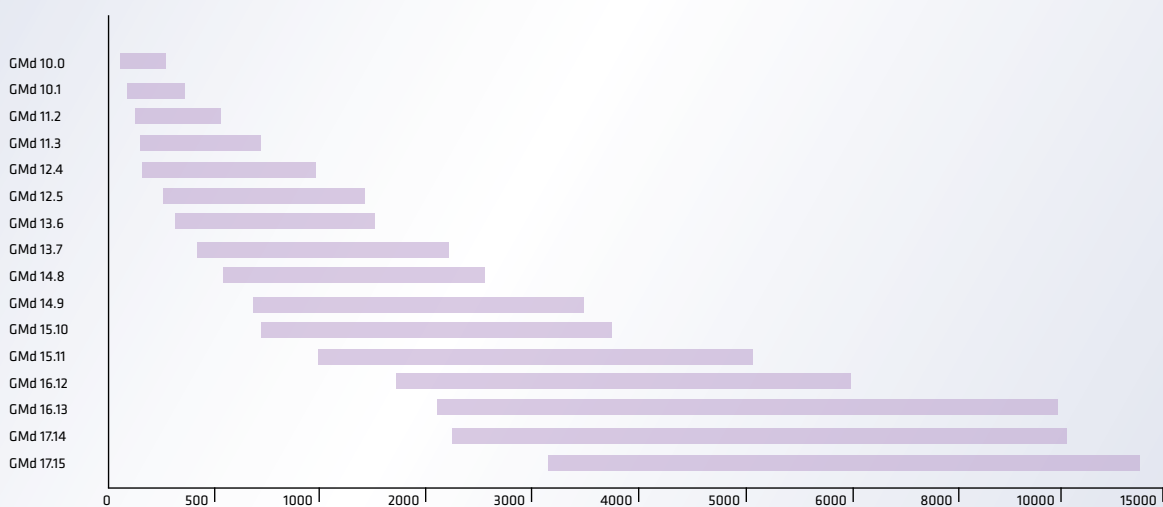

AT A GLANCE.

VARIETY FOR EVERY APPLICATION.

		Compressor oil-free type VR
Industrial gases	Air separation	
	Oxygen	
Coke, iron, and steel	Coke oven gas compression (COG)	✓
	(Blast) furnace gas (BFG)	✓
	Process and cooling gas in iron (DRI)	
	Sealing gas compression, direct reduction kilns (DRI)	✓
	Hydrogen reduction (hydrogen route)	✓
	Oxygen blowers (from AEL, PEM electrolysis)	
Oil and gas extraction and storage	Natural gas compression (onshore, offshore)	✓
	Pipeline Booster, compressor charge	✓
	Gas recovery (VRU)	✓
	Boil-off gas compression (BOG)	
	Propane, butane booster (LNG)	
	Helium recovery	
	Decarbonisation/tertiary oil production	✓
Chemical process industry	Ammonia synthesis (recycle gas compression)	
	Sodium production (rich gas, lean gas, humid CO2)	✓
	Lime kiln gas compression, combustion gas compression	✓
	Acetylene circular gas	
Petrochemicals, refineries	PSA feed gas, tail gas	✓
	Flare gas compression	✓
	Ethylene, propylene, olefin (feed-gas compression)	✓
	Butadiene (extractive distillation)	✓
	Styrene off-gas	✓
	Desulphurisation	✓
	VOC compression	
Industrial research and development	Circular processes (inert gases, flushing gases)	
	Helium compression in cryo plants	
Energy production	Turbine charging	✓
Renewable energies, Power to X	Hydrogen power supply (AEL, PEM electrolysis)	✓
	Oxygen use (saturated from AEL, PEM electrolysis)	
	Synthetic gas compression (hydrogen, carbon dioxide, methane)	✓
Glass industry	Oxygen blowers (melting furnace)	
	Tin bath protective atmosphere (hydrogen, nitrogen)	
Nuclear	Vapour recompression	
	Boron recycling	
Refrigeration technology	Compression of organic and inorganic coolants	
	Refrigeration circuits	

Compressor oil-injected type VMY	Blower oil-free type GR	Blower oil-free type GQ	Gas booster, high pres- sure, type GM dz	Gas booster, low pressure, type GMd
✓			✓	✓
	✓		✓	
	✓			
	✓	✓		
		✓		
✓				
	✓		✓	
✓				
✓				
✓	✓			✓
✓			✓	✓
✓	✓		✓	
✓				
✓	✓		✓	✓
✓				
	✓			
✓	✓		✓	✓
✓				
✓				
			✓	✓
	✓			
✓	✓		✓	
✓				
	✓		✓	✓
	✓		✓	✓
	✓			
	✓			
✓				
✓			✓	
	✓		✓	✓
	✓		✓	✓
	✓			
	✓			
✓				
✓				

EVERYTHING – EXCEPT ORDINARY. THE SERVICE WORLD OF AERZEN.

The long service life of AERZEN machines is legendary. So why is service an issue at all? Because it's about more than availability and OEM original parts. The services from AERZEN secure investments, productivity, and a decisive competitive edge. And this worldwide.



On site worldwide.

Our service teams work where our machines are. All over the world. Onshore or offshore. How do we reach you? With short distances. AERZEN has a dense network of service centres and decentralised parts warehouses around the globe. 2,500 employees work for AERZEN. On every continent. More than 200 excellently trained service technicians are ready to support you from there. Any time and anywhere you need us.

Just as individual as your applications.

AERZEN's service world has a lot on offer. Customised service kits, exchange stages, machine diagnostics, sound optimisation, and much more. One of our most important services is AERZEN Rental. This service offers a large fleet of rental machines: Blowers, turbo machines and compressors – made by AERZEN. In a wide range of performance classes. For all common pressure ranges. Can be used immediately and delivered turnkey on request. What does that mean for you? You are also well prepared for unexpected requirements.

Contact around the world

We service your German needs with six sales offices in Germany alone. With 50 subsidiaries in more than 100 countries around the world. We never have to travel far – on all continents. Give us a call:

+49 5154 81 0

Service Hotline

We are there for you, even if we are not actually there – outside our business hours. Use the direct line to AERZEN via our regional service hotlines:

+49 700 49318551

Rental Division

Renting instead of buying? Our AERZEN service with its wide portfolio of rental machines is the solution. Ready to use. And delivered turnkey worldwide, if needed:

www.aerzenrental.com

LET'S TALK. WE WILL BE HAPPY TO ADVISE YOU.

Every industry has its own requirements. We at AERZEN know the many challenges our customers face every day. To meet these requirements, we have developed high-performance process gas solutions, for smooth-running process flows and maximal efficiency.



AERZEN – A competent partner at your side.

Every industry is different. AERZEN has a wide range of customers in the field of process gas solutions. We know that every industry has its own special conditions, and are always ready to adapt to changing requirements. Specialist know-how and honest interest in the requirements of our customers distinguish us as a reliable partner.

We present you individual and customised solution models specifically tailored to your application. A well-functioning information flow in both directions is key to finding a successful solution. We are not only happy to advise, but also to listen closely, and get a clear understanding of the issue at hand.

Now that we've mentioned our individuality.

AERZEN process gas solutions are used in the most demanding industries worldwide. In fields such as chemistry, petrochemistry, energy production, or the food and pharmaceutical sector, requirements on plant design, engineering, documentation, and service are extraordinary, with special safety and environmental guidelines. This is why the machine does not determine the process, but the process determines the machine.

With more than 150 years of experience in the area of process gas solutions, AERZEN is always available for you. Let's talk about the safety and accuracy of fit of your process gas plants and shape progress together. Let's talk! We will be happy to advise you.

AERZEN. Compression – the key to our success.

Aerzener Maschinenfabrik was founded in 1864. In 1868, we built Europe's first positive displacement blower. In 1911, the first turbo blowers followed, in 1943 the first screw compressors, and in 2010 the first rotary lobe compressor package. Innovations made by AERZEN keep driving forward the development of compressor technology. Today, AERZEN is one of the longest established and most significant manufacturers of positive displacement blowers, rotary lobe compressors, screw compressors, and turbo blowers in the world. AERZEN is among the undisputed market leaders in many areas of application.

At 50 subsidiaries throughout the world, more than 2,500 experienced employees work intensely to advance progress in compressor technology. Their technological expertise, our international network of experts, and the constant feedback we get from our customers provide the basis for our success. AERZEN products and services set the standard. In terms of reliability, stability of value, and efficiency. Go ahead – challenge us!



FIND YOUR LOCAL CONTACT

www.aerzen.com/worldwide



Aerzener Maschinenfabrik GmbH
Reherweg 28 – 31855 Aerzen / Germany
Telefon: +49 5154 81 0 – Fax: +49 5154 81 9191
info@erzen.com – www.aerzen.com



AERZEN
EXPECT PERFORMANCE